

hülsta 

hülsta-werke Hüls GmbH & Co. KG
Karl-Hüls-Str. 1
D-48703 Stadtlohn
Tel. +49 (0) 2563 86-0
Fax +49 (0) 2563 86-1417
www.huelsta.com

Design and concept legally protected, subject to error, subject to alterations in colour and material in line with technological progress.



THE STAR – OF THE ENSEMBLE.

A coffee table can be anything, a functional asset in the design of the living room or an extravagant central highlight. All tables shown however have one thing in common: They are perfect down to the last detail. The diagonal millings of the CT 220 create a dynamic overall look. Solid oak highlights the natural yet elegant feel. Strong accents in anthracite structured lacquer provide an excellent contrast.

CT 230

01



02



CT 220

03

A coffee table with a clear statement: the CT 230 convinces with a straight-lined design in a confident manner – and is available in several sizes and versions. One of them is the combination of a natural oak table top with an additional top made from grey stained glass and an elegant metal powder coated substructure. A spacious drawer that is discreetly integrated into the table frame, offers further storage.

01 Coffee table 1030, natural oak, metal substructure: anthracite structured lacquer, stained glass.

02 Coffee table 1030, natural oak, Keramik storm nero, metal substructure: anthracite structured lacquer, stained glass.

03 Coffee table 1020, solid natural oak rough look, natural oak rough look, metal substructure: anthracite structured lacquer.

MAKING AN ELEGANT IMPACT.

Soft curves meet clean edges. The coffee table CT 240 perfectly combines the two. The rectangular table top and its glass counterpoint are supported by a frame that stands out due to its expressive arch.



01

CT 240



02

CT 250

The elegant CT 250 coffee table featuring two table tops provides ample storage. Combine it with the CT 250 side table, a matching higher companion for the coffee table. Whether placed as a soloist next to or in front of the sofa or as an unmistakable ensemble with the coffee table – both tables are designed in such a way that they can be pushed into one another.

01 Coffee table 1240, core walnut, stained glass, metal substructure: high-gloss chrome.

02 Coffee table 1250, 650, stained glass, metal substructure: high-gloss chrome.



CT 210



02

01



Soft curves are a distinctive feature of its classic yet extravagant design: Just like the PERSIS carcass, the solid table top of the CT 210 coffee table is tapered towards the edges. Instead of sharp angles, it has beautifully soft transitions. Its exceptional quality and timeless design allows the CT 210 to effortlessly fit into any room.

01 Coffee table 945, solid oak anthracite, metal substructure: powder-coated anthracite.
02 Coffee table 944, 945, 946, solid oak natura, metal substructure: powder-coated quartz.



CT 200

HARMONIOUS BY NATURE.

The CT 200 coffee table featuring a rounded triangular shape visually opens up the room in front of the sofa instead of closing it off as might happen with a rectangular shape. This version can be perfectly combined with the column table that bears the same name. As the column table is available in two heights, two units make a striking side table set.

01



02



01 Coffee table CT 200, natural oak, metal substructure: powder-coated anthracite (units 944).

02 Coffee table CT 200, ceramic storm nero, metal substructure: powder-coated anthracite (units 911).

01



If you love clean lines and soft curves, then the CT 200 coffee tables will be the perfect choice. They repeat the lines of the elliptical units of the living room range NAVIS, but also add an elegant note as a single piece or combined with one another.

01 Coffee table CT 200, ceramic zaha stone, column: powder-coated pure white (units 944, 945).

02 Coffee table CT 200, ceramic zaha stone, metal substructure: powder-coated pure white (Typen 911, 944).



CT 200

02



CT 180

02

CT 170

01



The CT 170 features an upper table top made from solid structured beech or solid natural oak. The lower top is made from clear glass. The arched supports are available in high-gloss chrome, matt chrome or wooden finish. The CT 170 comes in sizes 70 x 70 cm and 120 x 70 cm.

CT 180



This coffee table is available in two versions, square and rectangular. It offers two drawers, which open in opposite directions, allowing access to magazines or remote control from two sides. In terms of colours, this simplistic coffee table is available in two carcass finishes and three finishes for the table top.

01 Coffee table CT 170, solid natural oak, (item 171 coffee table, item 120 drawer).

02 Coffee table CT 180, pure white lacquer, concrete grey.

EXTRAORDINARY ARCHITECTURE AND STYLE.

A genuine wood veneered or lacquered table top on a plinth plus another table top in clear or Optiwhite clear glass, stained or bronzed glass: its exciting architecture gives the designer coffee table CT 160 an almost avant-garde look. Two tables can also be easily combined.



If you want to use your coffee table at different heights, the CT 110 featuring a stepless height-adjustment between 40 and 55 cm will be the perfect choice.

01 Coffee table CT 160, white lacquer, Optiwhite clear glass (item 1811).
02 Coffee table CT 110, white lacquer, rear-lacquered glass, black (item 09211).



CT 90

01



The CT 90 in 80 x 80 cm or 110 x 110 cm and the option to have a swivelling drawer allows you to create storage space suited to your individual requirements. The wide spectrum of versions is very impressive.

02



The 45.0 cm high CT 10 is available in sizes 70 x 70 cm, 90 x 90 cm and 120 x 70 cm. The upper table top is available in wood, lacquer, rear-lacquered glass, clear glass and satinized or stained glass. The lower table top is optionally lacquered or veneered.

- 01 Coffee table CT 90, core walnut, white lacquer, rear-lacquered glass, white (item 08292 / 80x80cm).
- 02 Coffee table CT 10, core walnut, satinized glass (item 07118 / 70x70cm).
- 03 Coffee table CT 10, natural oak, clear glass (item 096 / 90x90cm).



03

CT 10

PRODUCT OVERVIEW

The coffee table is the secret star in the living room, both as an accessory for the suite and as a practical unit. It becomes the grand focal point of any type of interior decor – in elegant metal, breezy glass, solid lacquer, fine wood or an exciting mixture of these, to suit your own preferences.

Coffee table / ancillary table CT 250

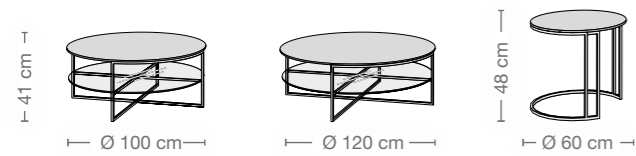

Upper tabletop of wood (lacquer or veneer), glass or ceramic, lower tabletop of glass, substructure of lacquered metal or in high-gloss chrome

Upper tabletop



Lower tabletop

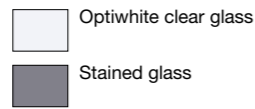

Metal substructure



Coffee table CT 240

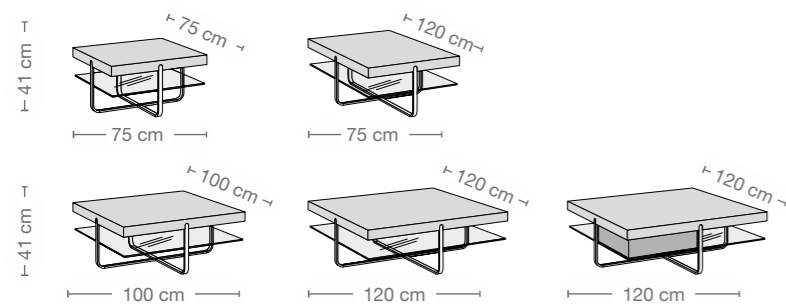

Upper tabletop of wood (lacquer or veneer), lower tabletop of glass, substructure of lacquered metal or in high-gloss chrome; optionally with revolving drawer

Upper tabletop

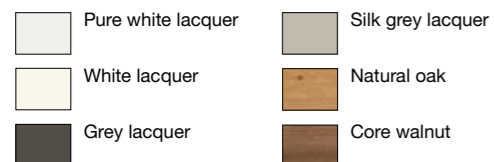

Lower tabletop

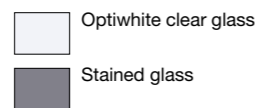

Metal substructure

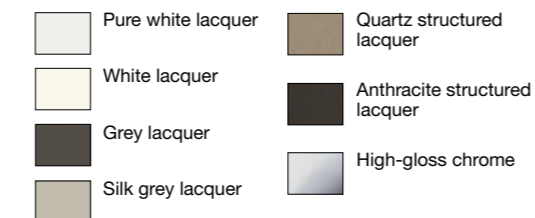

Coffee table CT 230

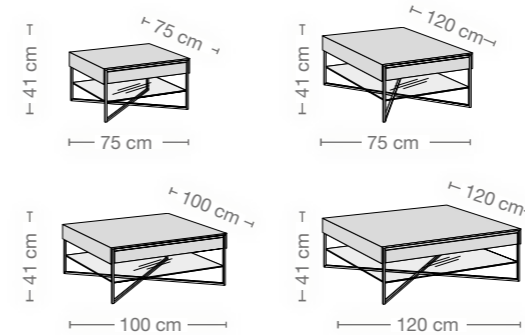

Upper tabletop of wood (lacquer or veneer) or ceramic, lower tabletop of glass, substructure of lacquered metal or in high-gloss chrome; optionally with drawer

Upper tabletop / upper side cover panel for ceramic versions



Lower tabletop

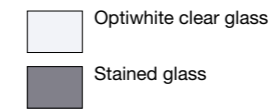

Metal substructure

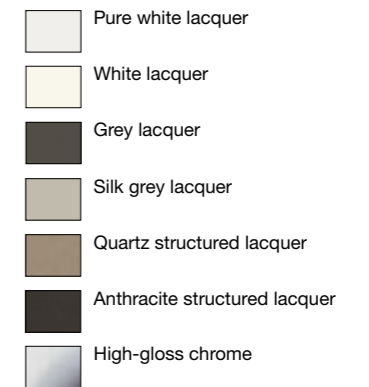

Coffee table CT 220

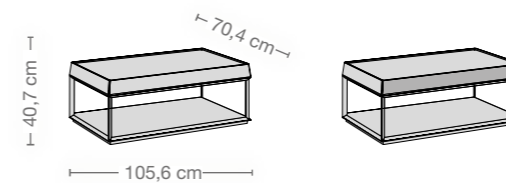

Tabletop in veneer or structured lacquer, lower tabletop in solid wood; optionally with drawer

Lower / Upper tabletop

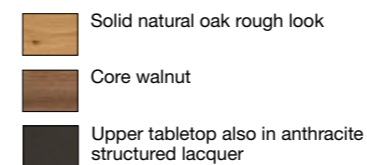

This overview shows individual examples. Further unit types and all ranges can be found in the type list. All dimensions in cm.

COFFEETABLES OVERVIEW

Coffee table CT 210

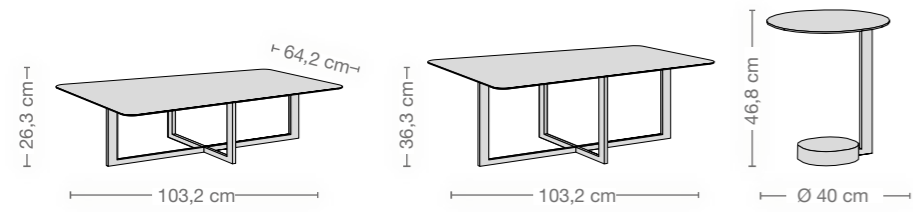

Tabletop of solid wood, substructure resp. column of powder-coated metal

Tabletop Table substructure



Coffee table CT 200

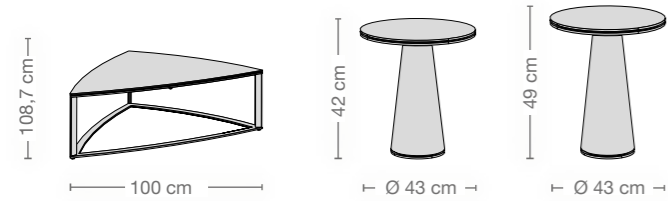

Tabletop of wood or ceramic, substructure resp. column of powder-coated metal

Tabletop Table substructure



Ancillary tables, bed shelf

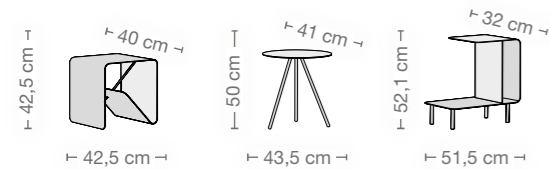

Ancillary tables and bed shelf of lacquered metal

Versions

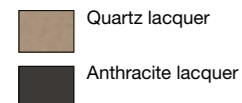

Coffee table CT 180

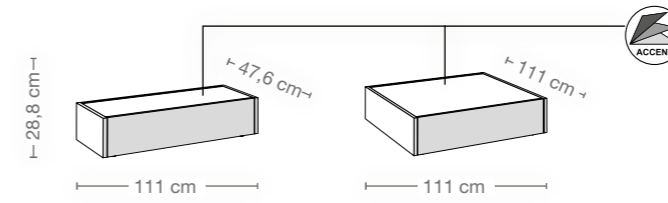

with drawers; tabletop optionally available in concrete grey version

Carcase, front, tabletop Accent tabletop



Coffee table CT 170

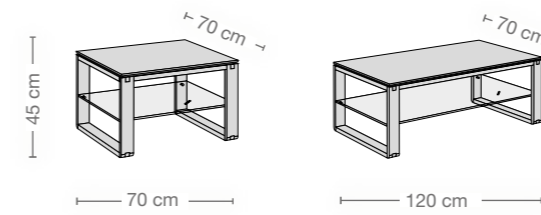

Upper tabletop of wood, lower tabletop of clear glass, arched supports in wood version, high-gloss chrome or matt chrome; with optional drawer

Upper tabletop Lower tabletop Arched supports



This overview shows individual examples. Further unit types and all ranges can be found in the type list. All dimensions in cm.

COFFEETABLES OVERVIEW

Coffee table CT 160

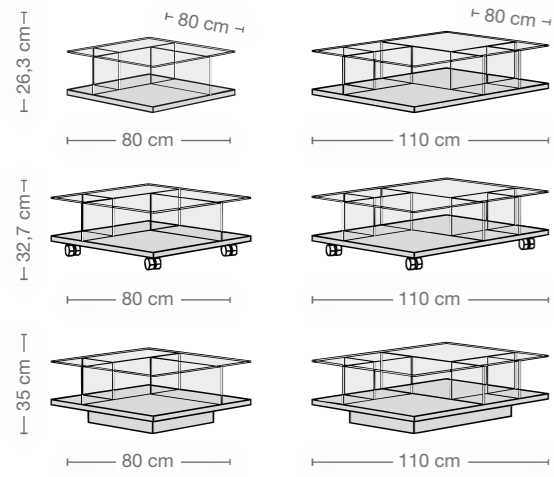

Superstructure of glass, lower tabletop veneered, lacquered or knotted wood; optionally with castors or plinth in high-gloss chrome

Upper tabletop

- Clear glass
- Stained glass
- Bronzed glass
- Optiwhite clear glass

Lower tabletop

- Pure white lacquer
- White lacquer
- Grey lacquer
- Natural oak
- Core walnut
- Knotted oak
- Knotted core walnut

Coffee table CT 110

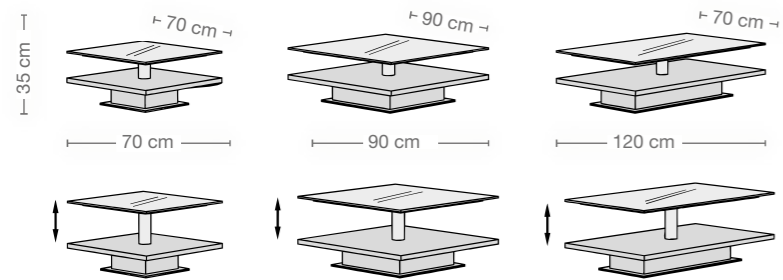

Base plate made of stainless steel; plinth and lower tabletop veneer or lacquer; column of metal, anthracite powder-coated; optionally with height adjustment

Plinth, lower tabletop

- White lacquer
- Natural oak
- Core walnut

Upper tabletop

- Rear-lacquered glass, white
- Rear-lacquered glass, grey
- Rear-lacquered glass, black

Coffee table CT 90

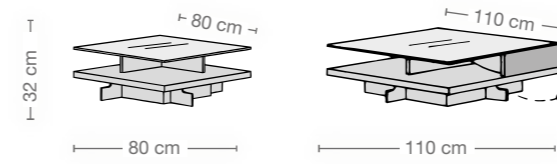

Upper tabletop of rear-lacquered glass, lower tabletop in matt lacquer; optionally with revolving drawer; revolving drawer optionally with LED-lamps

Lower tabletop

- White lacquer
- Grey lacquer
- Silk grey lacquer
- Black lacquer

Upper tabletop

- Rear-lacquered glass, white
- Rear-lacquered glass, grey
- Rear-lacquered glass, silk grey
- Rear-lacquered glass, black

Revolving drawer

- Natural oak
- Core walnut

Coffee table CT 10

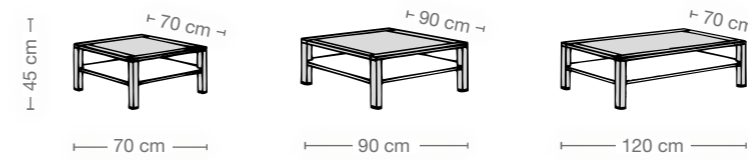

Upper tabletop in lacquer, veneer or of glass, lower tabletop in lacquer or veneer

Lower tabletop

- White lacquer
- Natural oak
- Core walnut

Upper tabletop

- White lacquer
- Natural oak
- Core walnut
- Rear-lacquered glass, white
- Rear-lacquered glass, grey

- Clear glass
- Stained glass
- Bronzed glass

This overview shows individual examples. Further unit types and all ranges can be found in the type list. All dimensions in cm.

LIVE QUALITY

hülsta stands for quality made in Germany. As a tradition-rich, third generation family business from the Münsterland, hülsta values perfect craftsmanship in combination with modern manufacturing processes, whilst always focussing on the responsible use of natural resources. hülsta therefore exclusively uses wood from sustainable sources and never tropical wood, thus reducing transportation and protecting the environment. That is why all modular units and base frames from hülsta have been carrying the “Blue Angel” since 1996, an award for products that are low in emissions and environmentally friendly. hülsta – durable furniture in harmony with nature.



All of the products are extensively tested and are subject to strict quality criteria. For new purchases, hülsta always grants a 5-year guarantee. Always inclusive: unlimited support for questions and requests regarding furniture from hülsta.



www.blauer-engel.de/uz38

The “Blue Angel” is subject to strict criteria. All modular units and base frames from hülsta have been awarded the “Blue Angel” since 1996 for being environmentally friendly and low in emissions.



Since 1974, hülsta has been part of the Deutsche Gütegemeinschaft Möbel (DGM) (German Quality Association for Furniture) and complies with their high standards for quality and consumer protection. hülsta effortlessly complies with the strict criteria that they use for their product testing.